

2400AT and 2400AIT Direct Wire Photoelectronic with Fixed Heat Smoke Detectors



A Division of Pittway
3825 Ohio Avenue, St. Charles, Illinois 60174
1-800-SENSOR2, FAX: 630-377-6495

Specifications

Size: Diameter:	5.5 inches (140 mm)
Height:	3.19 inches (81 mm); add 0.5 inches (13 mm) for thermal units
Weight:	0.7 lb. (310 g)
Air Velocity:	3000 ft/min (15 M/s)
Operating Temperature:	0° C to 38° C (0° to 100° F)
Operating Humidity:	10% to 93% Relative Humidity, noncondensing
Visual Indicator:	Solid State LED
Latching Alarm:	Reset by Momentary Power Interruption
Audible Signal:	85dBA minimum interrupted tone when in alarm or supply voltage polarity is reversed
Fixed Temperature Thermal:	135° F (57° C)

Electrical Ratings

System Voltage:	24 VDC
Maximum Ripple Voltage:	4 Volts peak-to-peak
Start-up Capacitance:	.02 μ F Maximum
Start-up Time:	36 Sec. Maximum
Voltage Limits:	10 – 32 VDC
Current Limits	
Standby:	120 μ A Maximum; 100 μ A Nominal
Alarm Current:	15mA at 10V; 67mA at 32V; 48mA at 24V
Reversed Supply:	5mA at 10V; 19mA at 32V; 15mA at 24V (Detector not in Alarm)
Alarm Impedance:	666 ohms Maximum; 478 ohms Minimum
Alarm Signal:	15mA Minimum in Alarm

Before Installing

Please thoroughly read the System Sensor manual I56-407-XX, *Guide for Proper Use of System Smoke Detectors*. This manual provides detailed information on detector spacing, placement, zoning, wiring, and special applications. It is available at no charge from System Sensor. (For installations in Canada refer to CAN/ULC4-S524, *Standard for the Installation of Fire Alarm Systems* and CEC Part 1, Sec. 32.)

General Description

System Sensor 2400AT and 2400AIT photoelectronic smoke detectors, listed to UL 268, provide open area protection and are intended for use with UL-listed, compatible, 2-wire control panels. The sensor in this detector operates on the light scattering principle and features a unique photo-optic sensing chamber that optimizes smoke entry while minimizing the effects of ambient light.

These detectors also provide restorable, 135° F fixed-temperature heat detection. The 2400AT heat detection unit is integrated with the photoelectronic sensor while the 2400AIT's heat detection unit is isolated from the photoelectronic smoke sensor and can be monitored separately. In addition, a piezoelectric horn in each detector produces

an interrupted, 85 dBA tone when the individual detector alarms or when the supply voltage polarity is reversed.

An LED on each detector lights to provide a local alarm indication and will remain on until the supply polarity is reversed. A screw terminal is provided for a remote LED annunciator optional accessory (RA400Z). These detectors also have the latching feature. The alarm can be reset only by momentary power interruption.

Mounting

Each 2400 Series detector is supplied with a mounting bracket kit to permit mounting in either of two ways:

1. Directly to a 3- or 4-inch octagonal, 1¹/₂-inch deep electrical box (See Figures 1 and 2).
2. To a 4-inch square electrical box by using a plaster ring with the mounting bracket kit supplied.

Spacing

NFPA 72E defines the spacing requirements for smoke detectors. Typically, this is 30 feet when the detectors are installed on a smooth ceiling. However, ALL installations must comply with NFPA 72E and/or special requirements of the authority having jurisdiction.

Figure 1. Flush mounting of detector on 4-inch octagonal box:

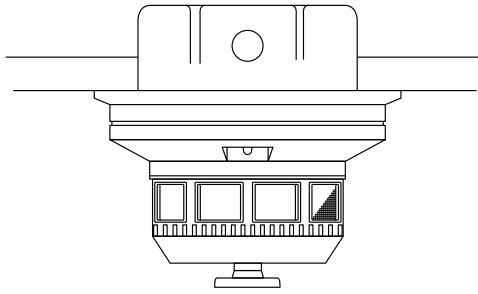

A78-1394-00

Installation Wiring Guidelines

All wiring must comply with the National Electrical Code and the applicable local codes, and any special requirements of the authority having jurisdiction, using the proper wire gauges. The conductors used to connect smoke detectors to control panels and accessory devices should be color-coded to reduce the likelihood of wiring errors. Improper connections can prevent a system from responding properly in the event of a fire.

For signal wiring (wiring between interconnected detectors), wiring no smaller than AWG 18 is recommended. The clamping plates in the base can accept wire sizes up to AWG 12. For best system performance, the power (+ and -) loop wires should be twisted pair and installed in separate grounded conduit or shielded cable to protect the loop from extraneous electrical interference. If a cable shield is provided, the shield connection to and from the detector must be made continuous by using wire nuts, crimping, or soldering, as appropriate for a reliable connection.

Wire connections are made by stripping about 3/8” insulation from the end of the wire, sliding the bare end of the wire under the clamping plate, and tightening the clamping plate screw. Do NOT loop the wire under the terminals. System Sensor smoke detectors are marked with a compatibility identifier located as the last digit of a five-digit code stamped on the back of the product. Connect detectors only to compatible control units as indicated in System Sensor’s compatibility chart. This chart contains a current list of UL-

Figure 2. Detector mounting bracket:

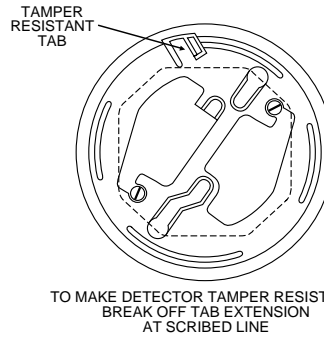

A78-534-00

listed control units and detector combinations and is available from System Sensor upon request.

CAUTION

Dust covers provide limited protection against airborne dust particles during shipping. Dust covers **MUST** be removed before the smoke detectors can sense smoke. Remove sensors before beginning remodeling or heavy construction.

Tamper-resistance Feature

The Tamper Resistant Tab, in the detector mounting bracket, can make the detector tamper-resistant by making it necessary to use a pocket screwdriver, or similar tool, to detach the detector from the bracket.

To make the detector tamper-resistant, use needle-nose pliers to break the smaller tab at the scribed line on the Tamper Resistant Tab. Figure 2 shows the location of this tab on the detector mounting bracket.

To remove a detector from the bracket after it has been made tamper-resistant, use a pocket screwdriver, or other similar tool, to depress the Tamper Resistant Tab, in the slot on the mounting bracket, and rotate the detector counter-clockwise.

Testing

NOTE: Before testing, notify the proper authorities that the smoke detector system is undergoing maintenance and, therefore, the system will be temporarily out of service. Disable the zone or system undergoing maintenance to prevent unwanted alarms.

Figure 3. Wiring diagram for 2400AT detector with two-wire control panel:

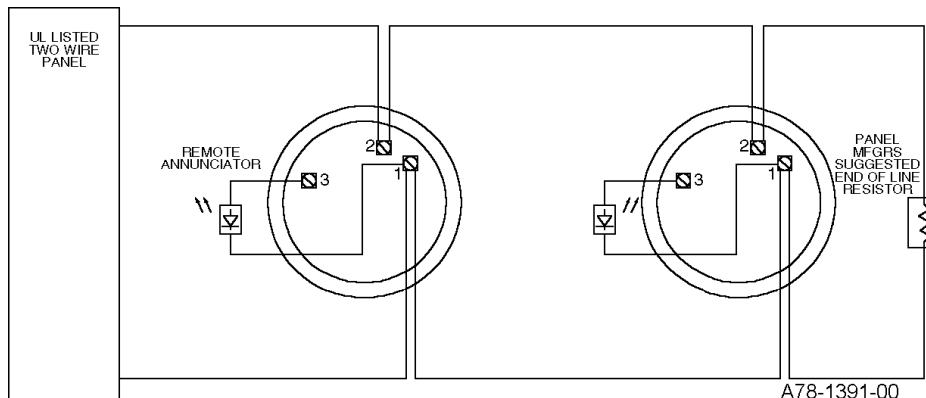

A78-1391-00

Figure 4. Wiring diagram for 2400AIT detector with isolated thermal and two-wire panels:

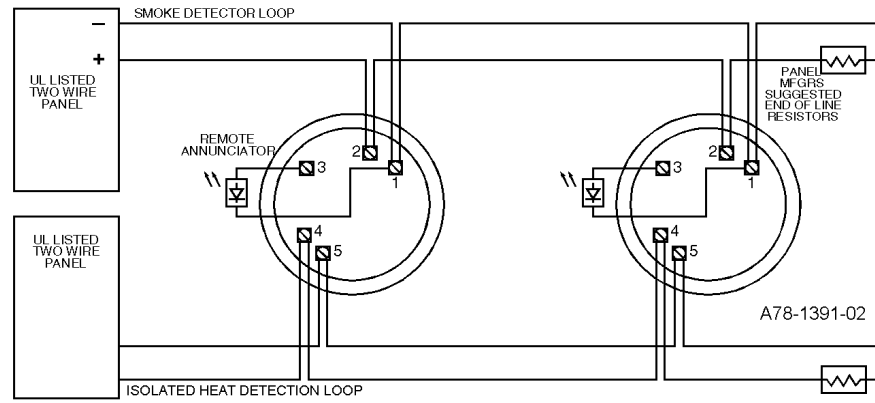

Detectors must be tested after installation and periodic maintenance. System Sensor 2400AT and 2400AIT Smoke Detectors can be tested in the following five ways:

NOTE: Before testing the detector, check for the presence of the flashing LED. If it does not flash, power has been lost (check the wiring), or it is defective (return for repair – refer to the Warranty).

A. Recessed Test Switch

1. Push and hold the recessed test switch with a 0.1 inch maximum diameter tool, such as a pocket screwdriver.
2. The LED on the detector should light within 5 seconds. The p-horn should also sound.

B. Calibrated Test Card (R59-18-00)

1. Remove the detector cover by placing a small bladed screwdriver in the side slot of the detector cover, twisting it slightly until the cover can be turned counterclockwise for removal.
2. Insert the NO ALARM end of the test card fully into the test slot (see Figure 6) and slide it counterclockwise until it stops.
3. The detector should not alarm (wait at least 20 seconds).
4. Remove the test card by sliding it clockwise before removing, then repeat with the ALARM end of the test card.
5. The LED should latch on within 20 seconds, indicat-

- ing alarm and annunciating the panel.
6. Replace the cover by gently rotating it clockwise until it locks in place.

C. Test Module (System Sensor Model No. MOD400R)

The MOD400R is used with an analog or digital voltmeter to check the detector sensitivity as described in the test module’s manual.

D. Aerosol Generator (Gemini 501)

Set the generator to represent 4% /Ft. to 5% /Ft. obscuration as described in the aerosol generator manual. Using the bowl shaped applicator, apply aerosol until the unit alarms.

E. Direct Heat Method (Hair dryer of 1000-1500 watts)

Direct the heat toward the bimetallic collector. Hold the heat source about 12 inches from the detector in order to avoid damage to the plastic. When the heat rises to greater than 135°F the detector will latch in alarm.

The detector will reset only after it has had sufficient time to cool and the power source has been temporarily interrupted. Both smoke and heat detection testing are recommended for verifying system protection capability.

Detectors that fail these tests should be cleaned as described under MAINTENANCE and retested. If the detectors still fail these tests, they should be returned for repair. Notify the proper authorities the system is back on line.

Figure 5. Bottom and side views, showing position of test switch:

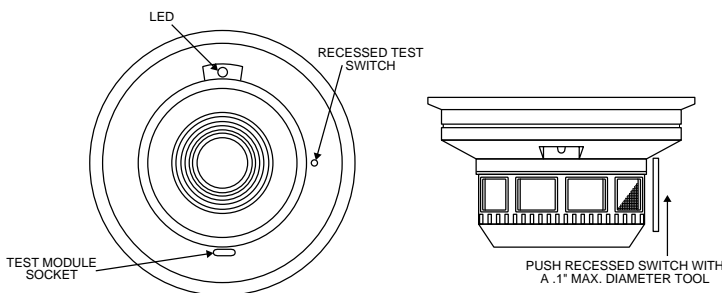

Maintenance

NOTE: Before cleaning, notify the proper authorities that the smoke detector system is undergoing maintenance and, therefore, will be temporarily out of service. Disable the system undergoing maintenance to prevent unwanted alarms.

1. Remove the detector cover by placing a small-bladed screwdriver in the side slot of the detector cover, twisting it until the cover can be turned counterclockwise for removal.
2. Vacuum the screen carefully without removing it. If further cleaning is required, continue with step 3, other-

wise skip to step 6.

3. Remove the screen by pulling it straight out. Vacuum the inside.
4. Clean the vaned chamber piece by vacuuming out dust and particles.
5. To replace the screen, orient it so that the arrow on top aligns with the field test socket on the base of the detector. Carefully push the screen onto the base making sure it fits tightly to the chamber.
6. Replace the cover by gently rotating it clockwise until it locks in place.

Figure 6:

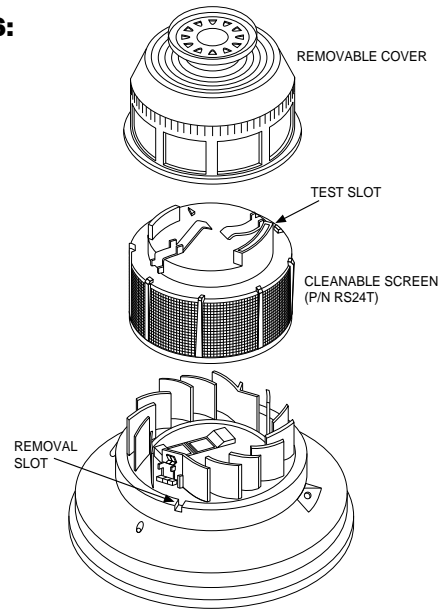

A78-1409-00

WARNING

The Limitations of Property Protection Smoke Detectors and Sounders

The sounder in this detector will not operate if the power is cut off for any reason.

The sounder may not be heard. The loudness of the sounder meets or exceeds the current standards. However, the sounder may not alert a sound sleeper or one who has recently used drugs or has been drinking alcoholic beverages. This sounder may not be heard if it is placed in an area which is separated by a closed door, or if it is located on a different floor from the person in a hazardous situation, or if it is placed too far away to be heard over the ambient noise such as traffic, air conditioners, machinery, or musical appliances that may prevent alert persons from hearing the alarm.

The sounder may not be heard by persons who are hearing impaired. In this case, a visual indicator shall also be used.

This smoke detector used with this base is designed to **activate and initiate** emergency action, but will do so only when used in conjunction with an authorized fire alarm system. This detector must be installed in accordance with NFPA standard 72.

Smoke detectors will not work without power. AC or DC powered smoke detectors will not work if the power supply is cut off .

Smoke detectors will not sense fires which start where smoke does not reach the detectors. Smoldering fires typically do not generate a lot of heat which is needed to drive smoke up to the ceiling where the smoke detector is usually located. For this reason, there may be large delays in detecting a smoldering fire with either an ionization-type detector or a photoelectric-type detector. Either one of them may alarm only after flaming has initiated, which will generate the heat needed to drive the smoke to the ceiling.

Smoke from fires in chimneys, in walls, on roofs, or on the other side of a closed door may not reach the smoke detector and alarm it. A detector

cannot quickly detect, or sense at all, a fire developing on another level of a building. For this reason, **detectors shall be located on every level and in every bedroom within a building.**

Smoke detectors have sensing limitations, too. Ionization detectors and photoelectric detectors are required to pass fire tests of the flaming and smoldering types. This is to ensure that both can detect a wide range of fires. Ionization detectors offer a broad range of fire-sensing capability, but they are somewhat better at detecting fast-flaming fires than slow-smoldering fires. Photoelectric detectors sense smoldering fires better than flaming fires, which have little, if any, visible smoke. Because fires develop in different ways, and are often unpredictable in their growth, neither type of detector is always best, and a given detector may not always provide early warning of a specific type of fire.

In general, detectors cannot be expected to provide warnings for fires resulting from inadequate fire protection practices, violent explosions, escaping gases that ignite, improper storage of flammable liquids like cleaning solvents that ignite, other similar safety hazards, arson, smoking in bed, children playing with matches or lighters, etc. Smoke detectors used in high air velocity conditions may have a delay in alarm due to dilution of smoke densities created by frequent and rapid air exchanges. Additionally, high air velocity environments may create increased dust contamination, demanding more frequent detector maintenance.

Smoke detectors cannot last forever. Smoke detectors contain electronic parts. Even though detectors are made to last over 10 years, any part can fail at any time. Therefore, smoke detectors shall be replaced after being in service for 10 years. The smoke detector system that this detector is used in must be tested regularly per NFPA 72. This smoke detector should be cleaned regularly per NFPA 72 or at least once a year.

Three-Year Limited Warranty

System Sensor warrants its enclosed smoke detector to be free from defects in materials and workmanship under normal use and service for a period of three years from date of manufacture. System Sensor makes no other express warranty for this smoke detector. No agent, representative, dealer, or employee of the Company has the authority to increase or alter the obligations or limitations of this Warranty. The Company's obligation of this Warranty shall be limited to the repair or replacement of any part of the smoke detector which is found to be defective in materials or workmanship under normal use and service during the three year period commencing with the date of manufacture. After phoning System Sensor's toll free number 800-SENSOR2 (736-7672) for a Return Authorization number, send defective units postage prepaid to: System Sensor, Repair Depart-

ment, RA # _____, 3825 Ohio Avenue, St. Charles, IL 60174. Please include a note describing the malfunction and suspected cause of failure. The Company shall not be obligated to repair or replace units which are found to be defective because of damage, unreasonable use, modifications, or alterations occurring after the date of manufacture. In no case shall the Company be liable for any consequential or incidental damages for breach of this or any other Warranty, expressed or implied whatsoever, even if the loss or damage is caused by the Company's negligence or fault. Some states do not allow the exclusion or limitation of incidental or consequential damages, so the above limitation or exclusion may not apply to you. This Warranty gives you specific legal rights, and you may also have other rights which vary from state to state.